

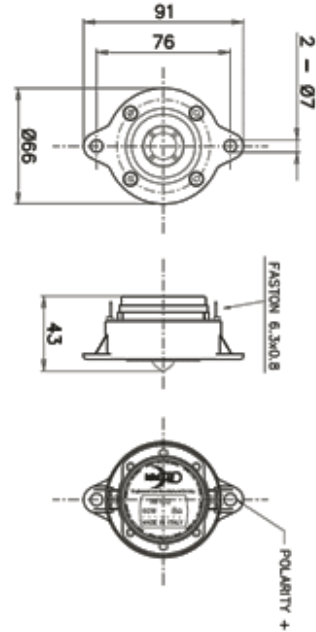

HF102 Compression Driver



NOMINAL SPECIFICATIONS

Throat Diameter	25,4 mm (1 in)
Overall Diameter	91 mm (3.58 in)
Depth	43 mm (1.69 in)
180° Mounting Holes Diameter (2xM6)	76 mm (2.99 in)
Net Weight	0.32 Kg (0.71 lb)
Shipping Box	147x130x82 mm (5.79x5.12x3.23 in)
Shipping Weight	0.4 Kg (0.88 lb)

ORDERING CODES

Faston Terminals - 8 Ohm Version	00253937
Faston Terminals - 16 Ohm Version	

ELECTRICAL SPECIFICATION

Nominal Impedance	8 ohm
Minimum Impedance	6.6 ohm
Re	6 ohm
Minimum Crossover Frequency *	2.6 kHz
Sensitivity (1W/1m) **	107 dB
Frequency Range	1.8÷20 kHz
Nominal Power Handling ***	30 W
Maximum Power Handling ****	60 W
Diaphragm Material	Ketone Polymer
Voice Coil Diameter	26 mm (1.02 in)
Winding Depth	1.7 mm (0.07 in)
Former Material	Kapton
Magnetic Gap Depth	2 mm (0.08 in)
Flux Density	1.3 T
Winding Material	Copper Clad Aluminium

NOTES

Driver mounted on LTH102 horn

Ferrofluid added in air gap

(*) 12 dB/oct or higher slope high-pass filter

(**) Averaged within the frequency range

(***) Test made for 2 hours with Pink Noise signal (6 dB Crest Factor) from minimum crossover frequency. Power calculated on rated minimum impedance. Driver mounted on aluminium horn.

(****) Maximum power is defined as 3dB greater than nominal power.

CURVES

